



Stone Concept

Questa pietra è utilizzata da secoli sia per il rivestimento murale dei nobili castelli francesi che per la loro pavimentazione, e proprio dalla pavimentazione di un castello nella valle della Loira è stata recuperata la particolare pietra a cui si ispira "Stone Concept", rendendo il design di questa serie assolutamente esclusivo ed irripetibile.

It has been used for centuries both for the wall coverings of noble French castles and for their paving, and it is from the paving of a castle in the Loire Valley that the particular stone which inspired "Stone Concept" was recovered, making the design of this series absolutely exclusive and unrepeatable.

Dieser Stein wird seit Jahrhunderten als Wand- und Bodenbelag in französischen Schlössern verwendet, und aus dem Bodenbelag eines Schlosses im Loire-Tal stammt jener besondere Stein, an dem sich "Stone Concept" inspiriert. Das macht das Design dieser Serie so einzigartig und unnachahmlich.

Cette pierre est utilisée depuis des siècles pour habiller les murs et les sols des splendides châteaux français, et c'est précisément dans un château de La Loire, sur son sol pour l'exactitude, qu'a été récupérée la pierre spéciale dont s'inspire « Stone Concept », une collection flanquée d'un style absolument exclusif et unique.

5

Colori
Colours
Farben
Couleurs

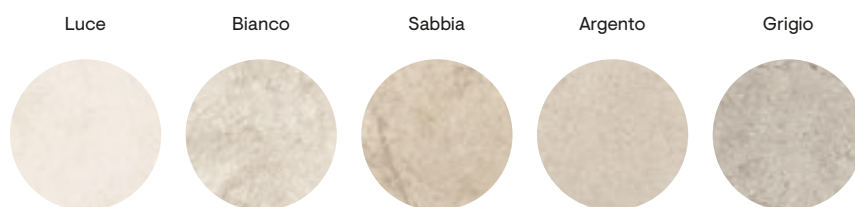

4

Formati
Sizes
Formate
Formats

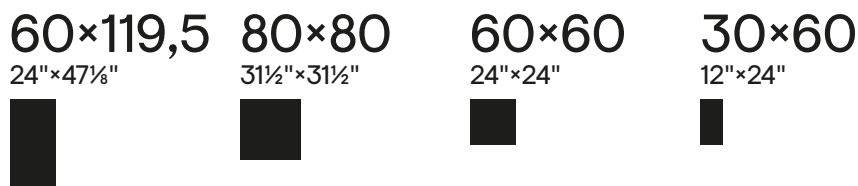

2

Spessori
Thickness
Stärke
Epaisseur

≙9,5 ≙10,5

3

Superfici
Surfaces
Oberflächen
Surfaces

Naturale Levigato Bocciardato

2

Strutture 3D
3D structures
Strukturen
Décorations en relief

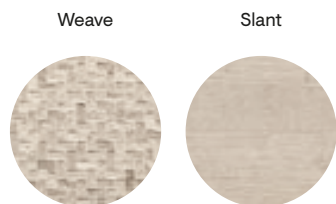

i

Effetto Pietra
Stone Look
Natursteinoptik
Effet Pierre

Rivestimento
Wall Tiles
Wandfliesen
Revêtement

Pavimento
Floor Tiles
Bodenfliesen
Sol

Gres fine porcellanato
Fine porcelain stoneware
Feinsteinzeug
Grès cérame fin

Tecnologia digitale
Digital technology
Digital technologie
Technologie numérique

Stone Concept





Stone Concept



Luce

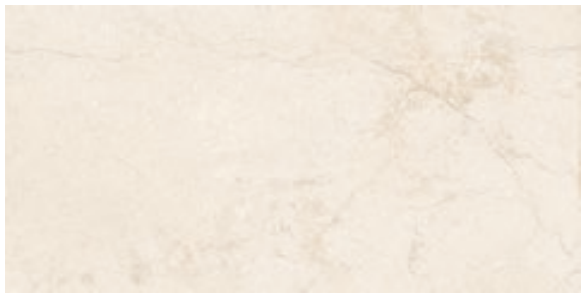

± 9,5

60×119,5

02506 | Stone Concept Luce Nat/Ret
02507 | Stone Concept Luce Lev/Ret

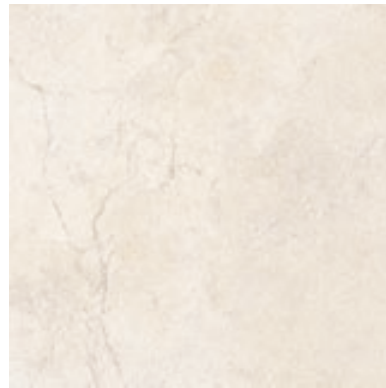

± 10,5

80×80

02511 | Stone Concept Luce Nat/Ret
02512 | Stone Concept Luce Lev/Ret



± 10,5

80×80

02513 | Stone Concept Luce Bocciardato/Ret



± 9,5

60×60

02504 | Stone Concept Luce Nat/Ret
02505 | Stone Concept Luce Lev/Ret

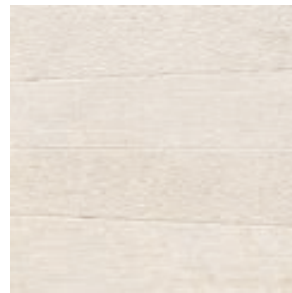

60×60

02509 | Stone Concept Slant Luce Ret



± 9,5

30×60

02501 | Stone Concept Luce Nat/Ret
02502 | Stone Concept Luce Lev/Ret



29×59

02514 | Stone Concept Brick Mix Luce Ret



30×60

02515 | Stone Concept Lines Luce Nat/Ret



30×60

02503 | Stone Concept Weave Luce Ret



30×30

02524 | Stone Concept Mosaico Luce Nat/Ret

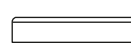

Stone Concept



Bianco

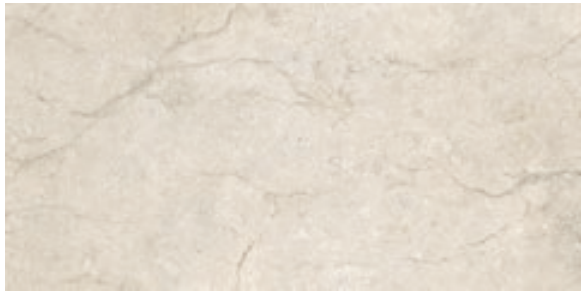

± 9,5

60×119,5

02227 | Stone Concept Bianco Nat/Ret
02232 | Stone Concept Bianco Lev/Ret



± 10,5

80×80

02242 | Stone Concept Bianco Nat/Ret
02246 | Stone Concept Bianco Lev/Ret



± 10,5

80×80

02313 | Stone Concept Bianco Bocciardato/Ret

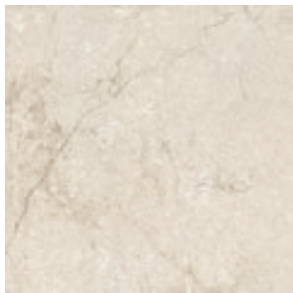

± 9,5

60×60

02218 | Stone Concept Bianco Nat/Ret
02223 | Stone Concept Bianco Lev/Ret

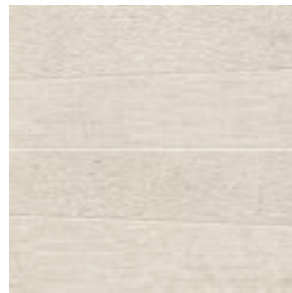

60×60

02305 | Stone Concept Slant Bianco Ret



± 9,5

30×60

02201 | Stone Concept Bianco Nat/Ret
02205 | Stone Concept Bianco Lev/Ret



29×59

02325 | Stone Concept Brick Mix Bianco Ret



30×60

02331 | Stone Concept Lines Bianco Nat/Ret



30×60

02209 | Stone Concept Weave Bianco Ret



30×30

02496 | Stone Concept Mosaico Bianco Nat/Ret

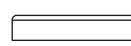
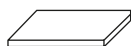

Stone Concept



Sabbia



± 9,5

60×119,5

02228 | Stone Concept Sabbia Nat/Ret
02233 | Stone Concept Sabbia Lev/Ret



± 10,5

80×80

02243 | Stone Concept Sabbia Nat/Ret
02247 | Stone Concept Sabbia Lev/Ret



± 10,5

80×80

02314 | Stone Concept Sabbia Bocciardato/Ret

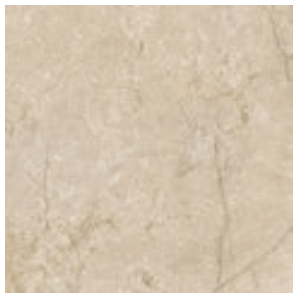

± 9,5

60×60

02219 | Stone Concept Sabbia Nat/Ret
02224 | Stone Concept Sabbia Lev/Ret

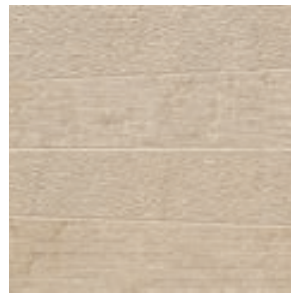

60×60

02306 | Stone Concept Slant Sabbia Ret



± 9,5

30×60

02202 | Stone Concept Sabbia Nat/Ret
02206 | Stone Concept Sabbia Lev/Ret



29×59

02326 | Stone Concept Brick Mix Sabbia Ret



30×60

02332 | Stone Concept Lines Sabbia Nat/Ret

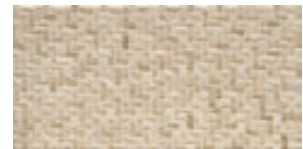

30×60

02211 | Stone Concept Weave Sabbia Ret



30×30

02497 | Stone Concept Mosaico Sabbia Nat/Ret

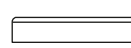

Stone Concept



Argento

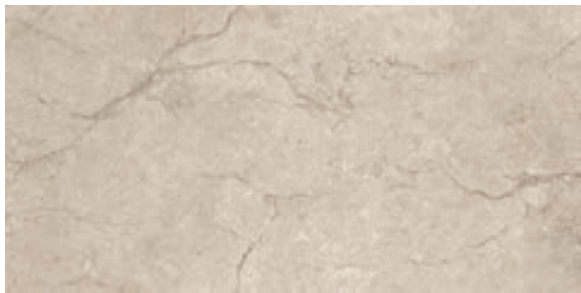

± 9,5

60×119,5

02229 | Stone Concept Argento Nat/Ret
02234 | Stone Concept Argento Lev/Ret



± 10,5

80×80

02244 | Stone Concept Argento Nat/Ret
02248 | Stone Concept Argento Lev/Ret



± 10,5

80×80

02315 | Stone Concept Argento Bocciardato/Ret

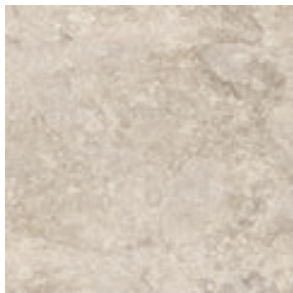

± 9,5

60×60

02221 | Stone Concept Argento Nat/Ret
02225 | Stone Concept Argento Lev/Ret



60×60

02307 | Stone Concept Slant Argento Ret

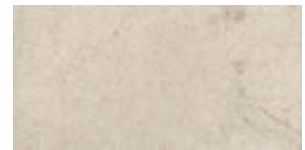

± 9,5

30×60

02203 | Stone Concept Argento Nat/Ret
02207 | Stone Concept Argento Lev/Ret



29×59

02327 | Stone Concept Brick Mix Argento Ret



30×60

02333 | Stone Concept Lines Argento Nat/Ret



30×60

02212 | Stone Concept Weave Argento Ret



30×30

02498 | Stone Concept Mosaico Argento Nat/Ret

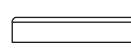

Grigio



± 9,5

60×119,5

02231 | Stone Concept Grigio Nat/Ret
02235 | Stone Concept Grigio Lev/Ret



± 10,5

80×80

02245 | Stone Concept Grigio Nat/Ret
02249 | Stone Concept Grigio Lev/Ret



± 10,5

80×80

02316 | Stone Concept Grigio Bocciardato/Ret



± 9,5

60×60

02222 | Stone Concept Grigio Nat/Ret
02226 | Stone Concept Grigio Lev/Ret



60×60

02308 | Stone Concept Slant Grigio Ret



± 9,5

30×60

02204 | Stone Concept Grigio Nat/Ret
02208 | Stone Concept Grigio Lev/Ret



29×59

02328 | Stone Concept Brick Mix Grigio Ret



30×60

02334 | Stone Concept Lines Grigio Nat/Ret



30×60

02213 | Stone Concept Weave Grigio Ret

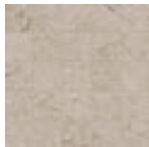

30×30



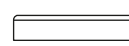
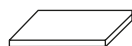



02499 | Stone Concept Mosaico Grigio Nat/Ret



Stone Concept

Imballi

Packing
Verpackung
Emballage

Formati Sizes		± MM	 Pezzi Scatola Pieces/Box Stck/Karton Carreaux/Boîte	 Mq/Scatola Sqmt/Box Qm/Karton M2/Boîte	 Kg/Scatola Kgs/Box Kg/Karton Kg/Boîte	 Scatole/Paletta Boxes/Pallet Karton/Palette Boîte/Palette	 Mq/Paletta Sqmt/Pallet Qm/Pallet M2/Palette	 Kg/Paletta Kgs/Pallet Kg/Pallet Kg/Palette	 Formato Paletta Size Pallet Format Pallet Dim. Palette
80×80 (31½"×31½") Nat/Ret - Lev/Ret - Bocc/Ret	P	10,5	2	1,280	31,50	40	51,20	1260	120x80x97
60×119,5 (24"×47½") Nat Ret	P	9,5	2	1,434	31,00	30	43,02	930	120x80x75
60×119,5 (24"×47½") Lev Ret	P	9,5	2	1,434	32,00	30	43,02	960	120x80x75
60×60 (24"×24") Nat/Ret	P	9,5	3	1,080	21,50	40	43,20	860	120x80x75
60×60 (24"×24") Lev/Ret	P	9,5	3	1,080	22,50	40	43,20	900	120x80x75
30×60 (12"×24") Nat/Ret	P	9,5	6	1,080	21,50	48	51,84	1032	120x80x75
30×60 (12"×24") Lev/Ret	P	9,5	6	1,080	22,50	48	51,84	1080	120x80x75
60×60 (24"×24") Slant Ret	P	9,5	3	1,080	21,50	40	43,20	860	120x80x75
30×60 (12"×24") Weave Ret	P	9,5	6	1,080	21,50	40	43,20	860	120x80x75
30×60 (12"×24") Lines Nat/Ret	P	9,5	4	0,720	14,30	21	15,12	300	120x80x75
29×59 - 11½"×23¼" Brick Mix Ret	P	9,5	4	0,684	14,30	16	10,95	228,8	120x80x75
30×30 (12"×12") Mosaico Nat/Ret	P	9,5	5	0,450	8,50	60	-	-	-









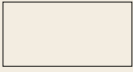

Pezzi Speciali / Special Pieces

30×119,5 (12"×47½") Gradino Nat/Ret	P	9,5	3	1,080	24,00	20	-	-	-
30×60 (12"×24") Gradino Nat/Ret	P	9,5	6	1,080	21,50	36	-	-	-
6,5×119,5 (2½"×47½") Battiscopa Nat/Ret - Lev/Ret	P	9,5	8	0,621	12,50	48	-	-	-
8×80 (3¼"×31½") Battiscopa Nat/Ret - Lev/Ret	P	10,5	7	0,448	11,00	65	-	-	-
8×60 (3¼"×24") Battiscopa Nat/Ret - Lev/Ret	P	9,5	10	0,480	11,00	72	-	-	-

Stone Concept

Riepilogo Gamma













Collection
Serie
Gamme

	Formati Sizes								Strutture 3D 3D Structures			
		60×119,5 24"×47½"	80×80 31½"×31½"	60×60 24"×24"	30×60 12"×24"	DIN 51130	DIN 51097	DCOF				
		± 9,5	± 10,5	± 9,5	± 9,5				Slant 60×60 24"×24"	Weave 30×60 12"×24"		
 Luce	Nat/Ret	02506	02511	02504	02501	V2	R10	A+B	>0.42	02509	02503	
	Lev/Ret	02507	02512	02505	02502							
	Bocciardato/Ret		02513				R11	A+B+C	>0.42			
 Bianco	Nat/Ret	02227	02242	02218	02201	V2	R10	A+B	>0.42	02305	02209	
	Lev/Ret	02232	02246	02223	02205							
	Bocciardato/Ret		02313				R11	A+B+C	>0.42			
 Sabbia	Nat/Ret	02228	02243	02219	02202	V2	R10	A+B	>0.42	02306	02211	
	Lev/Ret	02233	02247	02224	02206							
	Bocciardato/Ret		02314				R11	A+B+C	>0.42			
 Argento	Nat/Ret	02229	02244	02221	02203	V2	R10	A+B	>0.42	02307	02212	
	Lev/Ret	02234	02248	02225	02207							
	Bocciardato/Ret		02315				R11	A+B+C	>0.42			
 Grigio	Nat/Ret	02231	02245	02222	02204	V2	R10	A+B	>0.42	02308	02213	
	Lev/Ret	02235	02249	02226	02208							
	Bocciardato/Ret		02316				R11	A+B+C	>0.42			

Stone Concept

Riepilogo Gamma

Collection
Serie
Gamme

		Formati Sizes			Pezzi Speciali Special Pieces				
									
		Lines 30x60 12"x24"	Brick Mix 29x59 11½"x23¼"	Mosaico 30x30 12"x12"	Gradino 30x119,5 12"x47½"	Gradino 30x60 12"x24"	Battiscopa 6,5x119,5 2½"x47½"	Battiscopa 8x80 3½"x31½"	Battiscopa 8x60 3½"x24"
		± 9,5	± 9,5	± 9,5	± 9,5	± 9,5	± 10,5	± 9,5	
 Luce	Nat/Ret	02515	02514	02524	02523	02522	02518	02520	02516
	Lev/Ret						02519	02521	02517
 Bianco	Nat/Ret	02331	02325	02496	02358	02353	02343	02348	02337
	Lev/Ret						02396	02401	02391
 Sabbia	Nat/Ret	02332	02326	02497	02359	02354	02344	02349	02338
	Lev/Ret						02397	02402	02392
 Argento	Nat/Ret	02333	02327	02498	02361	02355	02345	02350	02339
	Lev/Ret						02398	02403	02393
 Grigio	Nat/Ret	02334	02328	02499	02362	02356	02346	02351	02341
	Lev/Ret						02399	02404	02394

Stone Concept

5 COLOURS

4 SIZES

3 SURFACES

A collection inspired by white Burgundy stone; a sedimentary rock, which can take on various aspects, because it includes delicate colour patches and veins.

Una collezione che si ispira alla pietra di borgogna bianca; una roccia calcarea sedimentaria, che può assumere varie apparenze, perché include delicate macchie di colore e vene.

Diese Kollektion ist am weißen Burgunderstein inspiriert, einem Kalkstein, der mit seinen zarten Farbflecken und Äderungen unterschiedliche Ausprägungen annehmen kann.

Une collection inspirée de la pierre blanche de Bourgogne: une roche sédimentaire calcaire qui peut avoir plusieurs aspects en raison de ses délicates taches colorées et veines.

Stone Concept



Spazi Residenziali
Residential Spaces

P. 5

Spazi Pubblici
Public Areas

P. 17

Informazioni Tecniche
Technical Information

P. 27

Questa pietra è utilizzata da secoli sia per il rivestimento murale dei nobili castelli francesi che per la loro pavimentazione, e proprio dalla pavimentazione di un castello nella valle della Loira è stata recuperata la particolare pietra a cui si ispira “Stone Concept”, rendendo il design di questa serie assolutamente esclusivo ed irripetibile.

This stone has been used for centuries both for the wall coverings of noble French castles and for their paving, and it is from the paving of a castle in the Loire Valley that the particular stone which inspired “Stone Concept” was recovered, making the design of this series absolutely exclusive and unrepeatable.

Dieser Stein wird seit Jahrhunderten als Wand- und Bodenbelag in französischen Schlössern verwendet, und aus dem Bodenbelag eines Schlosses im Loire-Tal stammt jener besondere Stein, an dem sich „Stone Concept“ inspiriert. Das macht das Design dieser Serie so einzigartig und unnachahmlich.

Cette pierre est utilisée depuis des siècles pour habiller les murs et les sols des splendides châteaux français, et c’est précisément dans un château de La Loire, sur son sol pour l’exactitude, qu’a été récupérée la pierre spéciale dont s’inspire « Stone Concept », une collection flanquée d’un style absolument exclusif et unique.

Spazi Residenziali

Residential Spaces
Wohnanlagen
Espaces Résidentiels



COLORI / COLOURS

AMBIENTI / AMBIENT

PAGINA / PAGE

Sabbia

Entrance

7

Sabbia

Living

8

Luce

Bathroom

10

Argento

Terrace

13

Stone Concept
Residential Spaces

5

Sabbia

Sober nuances, legible veins, and soft colour variations enhance the singularity of a timeless collection, inspired by the stones recovered from old dwellings.

Einfache Nuancen, deutliche Äderungen und zarte Farbvariationen unterstreichen die Einzigartigkeit einer zeitlosen Kollektion, die alte Steine aus historischen Anwesen zum Vorbild hat.

Les délicates nuances, les veines apparentes et les légères variantes de couleurs exaltent la singularité d'une collection atemporelle qui puise son inspiration dans les pierres des demeures anciennes.

Sobrie sfumature, venature leggibili, e tenui variazioni cromatiche esaltano l'unicità di una collezione senza tempo, ispirata alle pietre recuperate da antiche dimore.

30x60 - 12"x24" Levigato Rettificato



Stone Concept
Residential Spaces



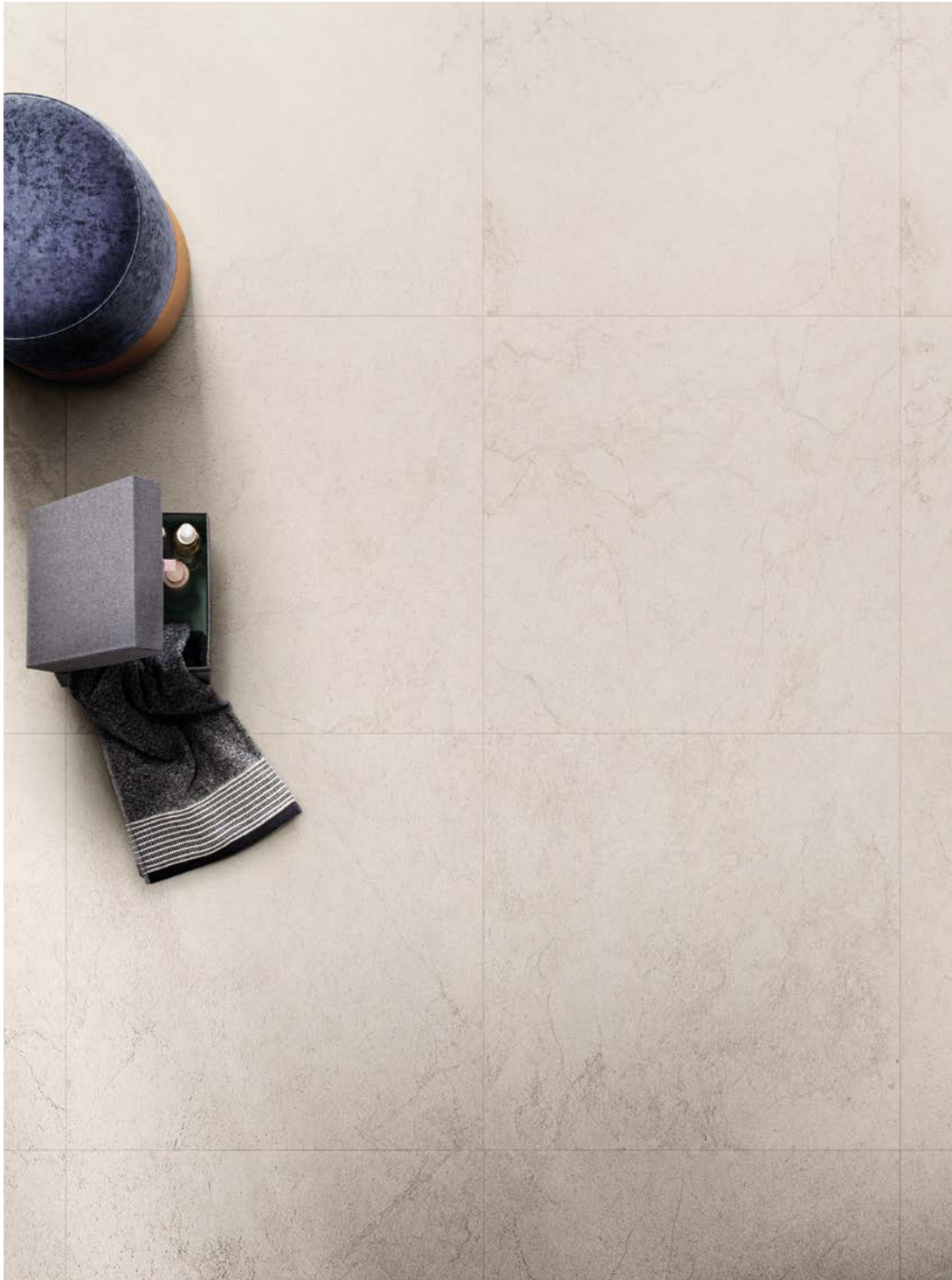

Argento

The outdoor slabs with bush-hammered finish ensure strong adherence and their natural look reinterprets the qualities of stone materials.

Die Platten für Außenverkleidungen mit gekrönelter Oberfläche garantieren gute Haftung und zeichnen sich durch ein natürliches Aussehen aus, das die Besonderheit des Steinmaterials neu interpretiert.

Les dalles d'extérieur, avec finition bouchardée, garantissent une très grande adhérence et affichent un aspect naturel incarnant toutes les valeurs de la pierre.

Le lastre per esterno con finitura bocciardata garantiscono requisiti di elevata aderenza e propongono un aspetto naturale che reinterpreta le qualità dei materiali lapidei.

80×80 - 31½"×31½" Bocciardato Rettificato



Stone Concept
Residential Spaces



Spazi Pubblici

Public Areas
Öffentliche Räumlichkeiten
Espaces Publics

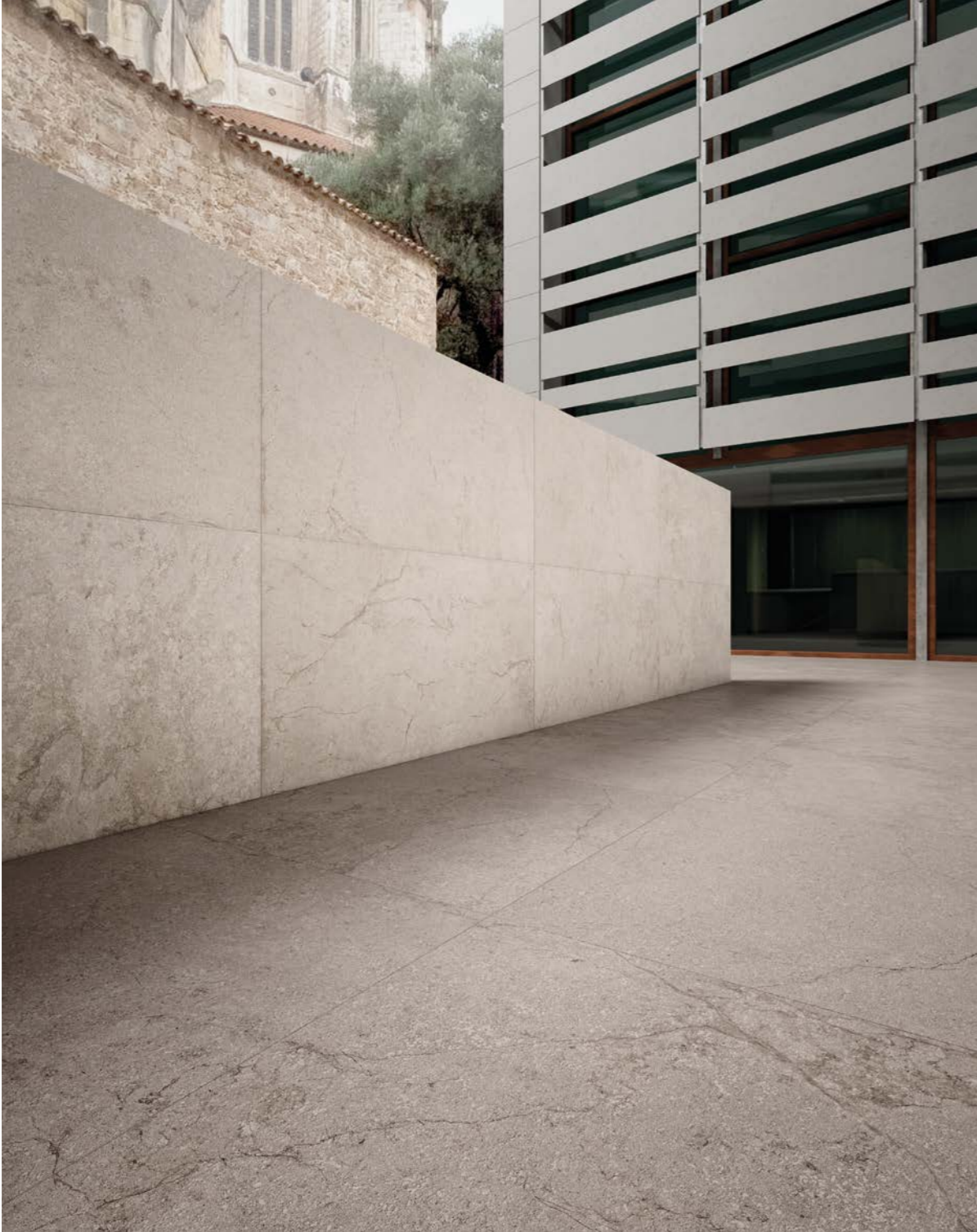

COLORI / COLOURS

AMBIENTI / AMBIENT

PAGINA / PAGE

Grigio	Food Court	18
Grigio / Argento	Public Outdoor	21
Sabbia	Museum	22
Argento	Bathroom	24



Grigio / Argento

The appeal of stone transposed onto ceramic material at the service of contemporary architecture.

Die auf Keramik übertragene Magie des Natursteins im Dienst der zeitgenössischen Architektur.

Le charme de la pierre transposée sur céramique au service de l'architecture contemporaine.

Il fascino della pietra trasposto sul materiale ceramico a servizio dell'architettura contemporanea.

80x80 - 31½"x31½" Bocciardato Rettificato

60x119,5 - 24"x47½" Naturale Rettificato

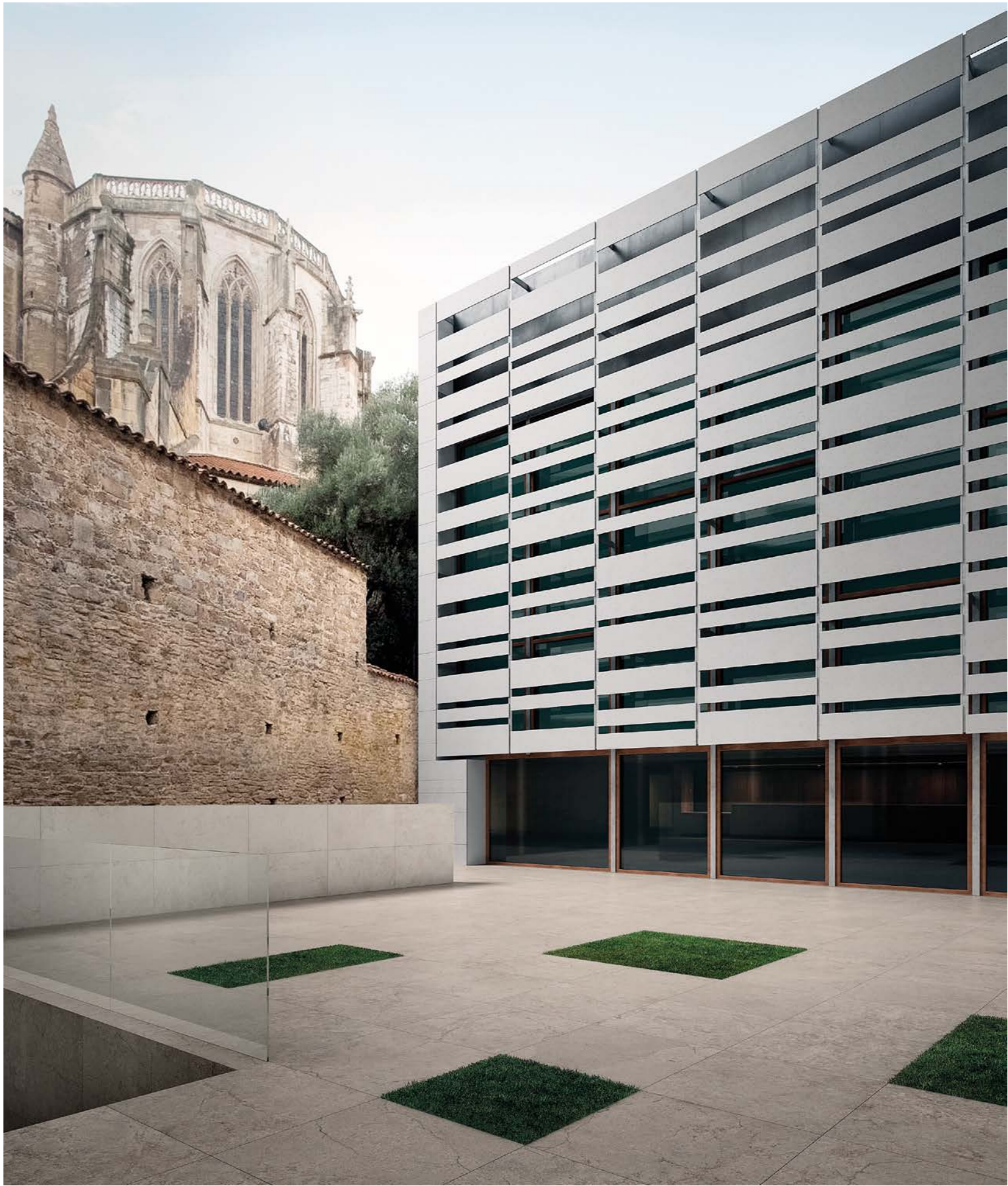

Stone Concept
Public Areas

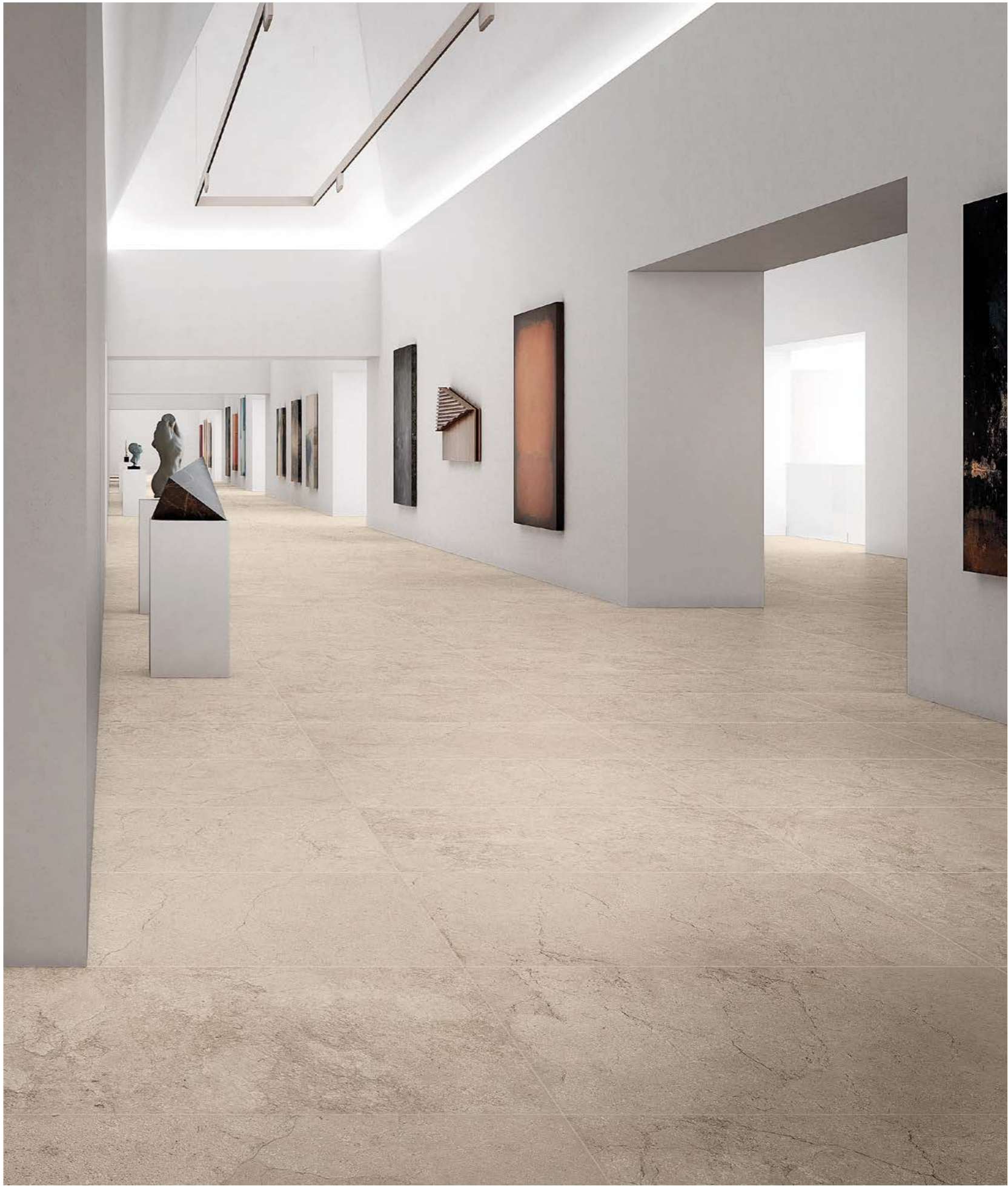

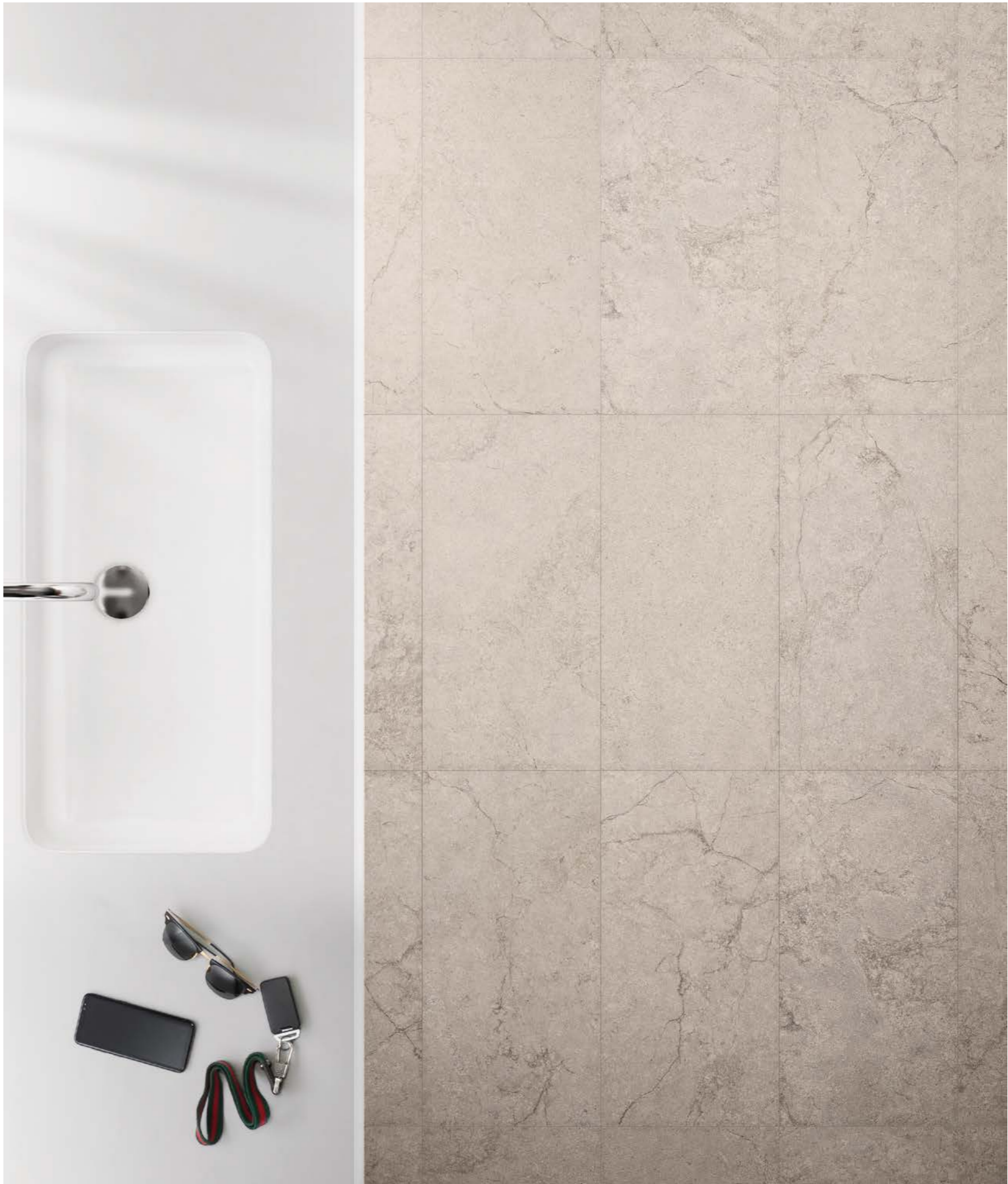

Informazioni Tecniche

5

Colori
Colours
Farben
Couleurs

Luce



Bianco

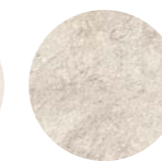

Sabbia

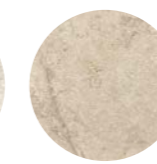

Argento

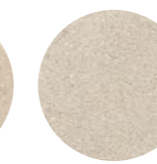

Grigio

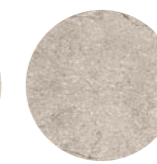

4

Formati
Sizes
Formate
Formats

60×119,5
24"×47½"



*80×80
31½"×31½"



60×60
24"×24"



30×60
12"×24"



2

Spessori
Thickness
Stärke
Epaisseur

±9,5

±10,5

3

Superfici
Surfaces
Oberflächen
Surfaces

Naturale

Levigato

Bocciardato

i

Effetto Pietra
Stone Look
Natursteinoptik
Effet Pierre

Rivestimento
Wall Tiles
Wandfliesen
Revêtement

Pavimento
Floor Tiles
Bodenfliesen
Sol

Gres fine porcellanato
Fine porcelain stoneware
Feinsteinzeug
Grès cérame fin

Tecnologia digitale
Digital technology
Digital technologie
Technologie numérique

*Attenzione: verificare in fase di ordine il codice e l'imballo (80×80)

*Note: In the ordering phase please check code and packaging (80×80)

*Bitteachten: Beim Bestellen bitte die Kodenummer und die Verpackung kontrollieren (80×80)

*Attention : Merci de vérifier emballage et la référence au moment de la commande (80×80)



Luce



± 9,5

60x119,5 - 24"x47½"
02506 | Stone Concept Luce Nat/Ret
02507 | Stone Concept Luce Lev/Ret



± 9,5*
± 10,5

80x80 - 31½"x31½"
02511 | Stone Concept Luce Nat/Ret
03686 | Stone Concept Luce Lev/Ret*



± 10,5

80x80 - 31½"x31½"
02513 | Stone Concept Luce Bocciardato/Ret

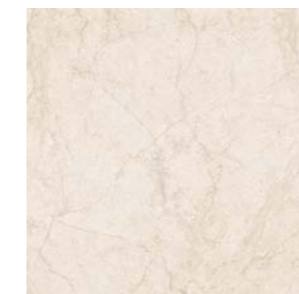

± 9,5

60x60 - 24"x24"
02504 | Stone Concept Luce Nat/Ret
02505 | Stone Concept Luce Lev/Ret

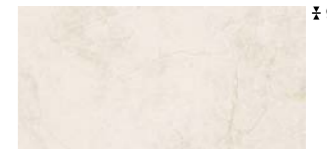

± 9,5

30x60 - 12"x24"
02501 | Stone Concept Luce Nat/Ret
02502 | Stone Concept Luce Lev/Ret

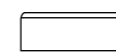



Bianco



± 9,5

60×119,5 - 24"×47½"

02227 | Stone Concept Bianco Nat/Ret
02232 | Stone Concept Bianco Lev/Ret



± 10,5

80×80 - 31½"×31½"

02242 | Stone Concept Bianco Nat/Ret
02246 | Stone Concept Bianco Lev/Ret



± 10,5

80×80 - 31½"×31½"

02313 | Stone Concept Bianco Bocciardato/Ret



± 9,5

60×60 - 24"×24"

02218 | Stone Concept Bianco Nat/Ret
02223 | Stone Concept Bianco Lev/Ret

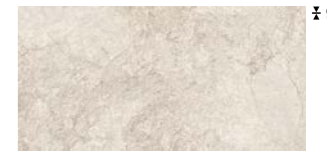

± 9,5

30×60 - 12"×24"

02201 | Stone Concept Bianco Nat/Ret
02205 | Stone Concept Bianco Lev/Ret

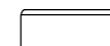



Sabbia



± 9,5

60x119,5 - 24"x47½"

02228 | Stone Concept Sabbia Nat/Ret
02233 | Stone Concept Sabbia Lev/Ret



± 10,5

80x80 - 31½"x31½"

02243 | Stone Concept Sabbia Nat/Ret
02247 | Stone Concept Sabbia Lev/Ret



± 10,5

80x80 - 31½"x31½"

02314 | Stone Concept Sabbia Bocciardato/Ret

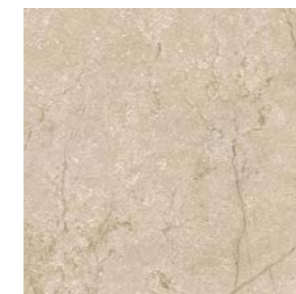

± 9,5

60x60 - 24"x24"

02219 | Stone Concept Sabbia Nat/Ret
02224 | Stone Concept Sabbia Lev/Ret

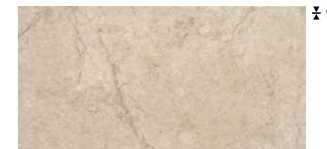

± 9,5

30x60 - 12"x24"

02202 | Stone Concept Sabbia Nat/Ret
02206 | Stone Concept Sabbia Lev/Ret

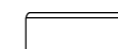



Argento



± 9,5

60x119,5 - 24"x47½"

02229 | Stone Concept Argento Nat/Ret
02234 | Stone Concept Argento Lev/Ret



± 10,5

80x80 - 31½"x31½"

02244 | Stone Concept Argento Nat/Ret
02248 | Stone Concept Argento Lev/Ret



± 10,5

80x80 - 31½"x31½"

02315 | Stone Concept Argento Bocciardato/Ret



± 9,5

60x60 - 24"x24"

02221 | Stone Concept Argento Nat/Ret
02225 | Stone Concept Argento Lev/Ret

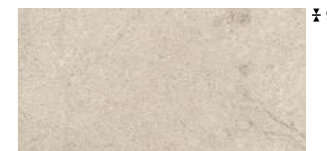

± 9,5

30x60 - 12"x24"

02203 | Stone Concept Argento Nat/Ret
02207 | Stone Concept Argento Lev/Ret

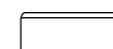



Grigio



± 9,5

60×119,5 - 24"×47½"

02231 | Stone Concept Grigio Nat/Ret
02235 | Stone Concept Grigio Lev/Ret



± 10,5

80×80 - 31½"×31½"

02245 | Stone Concept Grigio Nat/Ret
02249 | Stone Concept Grigio Lev/Ret



± 10,5

80×80 - 31½"×31½"

02316 | Stone Concept Grigio Bocciardato/Ret



± 9,5

60×60 - 24"×24"

02222 | Stone Concept Grigio Nat/Ret
02226 | Stone Concept Grigio Lev/Ret



± 9,5

30×60 - 12"×24"

02204 | Stone Concept Grigio Nat/Ret
02208 | Stone Concept Grigio Lev/Ret

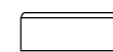

Riepilogo Gamma

Collection
Serie
Gamme

	Formati Sizes						Din 51130	Din 51097	Dcof		
		60x119,5 - 24"x47½"	80x80 - 31½"x31½"	80x80 - 31½"x31½"	60x60 - 24"x24"	30x60 - 12"x24"					
		± 9,5	± 9,5	± 10,5	± 9,5	± 9,5					
	Nat/Ret	02506		02511	02504	02501	V2	R10	A+B	>0.42	
	Lev/Ret	02507	03686		02505	02502					
	Bocciardato/Ret			02513				R11	A+B+C	>0.42	
	Nat/Ret	02227		02242	02218	02201	V2	R10	A+B	>0.42	
	Lev/Ret	02232		02246	02223	02205					
	Bocciardato/Ret			02313				R11	A+B+C	>0.42	
	Nat/Ret	02228		02243	02219	02202	V2	R10	A+B	>0.42	
	Lev/Ret	02233		02247	02224	02206					
	Bocciardato/Ret			02314				R11	A+B+C	>0.42	
	Nat/Ret	02229		02244	02221	02203	V2	R10	A+B	>0.42	
	Lev/Ret	02234		02248	02225	02207					
	Bocciardato/Ret			02315				R11	A+B+C	>0.42	
	Nat/Ret	02231		02245	02222	02204	V2	R10	A+B	>0.42	
	Lev/Ret	02235		02249	02226	02208					
	Bocciardato/Ret			02316				R11	A+B+C	>0.42	

*Attenzione: verificare in fase di ordine il codice e l'imballo (80x80)
 *Note: In the ordering phase please check code and packaging (80x80)
 *Bitteachten: Beim Bestellen bitte die Kodenummer und die Verpackung kontrollieren (80x80)
 *Attention : Merci de vérifier emballage et la référence au moment de la commande (80x80)

Riepilogo Gamma

Collection
Serie
Gamme

	Formati Sizes				
		Step 30x60 - 12"x24"	Battiscopa 6,5x119,5 - 2½"x47½"	Battiscopa 8x80 - 3½"x31½"	Battiscopa 8x60 - 3½"x24"
		± 9,5	± 9,5	± 10,5	± 9,5
	Nat/Ret	02522	02518	02520	02516
	Lev/Ret		02519	02521	02517
	Nat/Ret	02353	02343	02348	02337
	Lev/Ret		02396	02401	02391
	Nat/Ret	02354	02344	02349	02338
	Lev/Ret		02397	02402	02392
	Nat/Ret	02355	02345	02350	02339
	Lev/Ret		02398	02403	02393
	Nat/Ret	02356	02346	02351	02341
	Lev/Ret		02399	02404	02394

Imballi

Packing
Verpackung
Emballage

Formati Sizes	± MM	 Pezzi Scatola Pieces/Box Stck/Karton Carreaux/Boite	 Mq/Scatola Sqmt/Box Qm/Karton M2/Boite	 Kg/Scatola Kgs/Box Kg/Karton Kg/Boite	 Scatole/Paletta Boxes/Pallet Karton/Palette Boite/Palette	 Mq/Paletta Sqmt/Pallet Qm/Pallet M2/Palette	 Kg/Paletta Kgs/Pallet Kg/Pallet Kg/Palette	 Formato Paletta Size Pallet Format Pallet Dim. Palette
*80*80 (31½"×31½") Nat/Ret - Lev/Ret - Bocc/Ret	P 9,5	2	1,280	27,50	50	64,00	1375	120x80x96
80*80 (31½"×31½") Nat/Ret - Lev/Ret - Bocc/Ret	P 10,5	2	1,280	31,50	40	51,20	1260	120x80x97
60*119,5 (24"×47½") Nat Ret	P 9,5	2	1,434	31,00	30	43,02	930	120x80x75
60*119,5 (24"×47½") Lev Ret	P 9,5	2	1,434	32,00	30	43,02	960	120x80x75
60*60 (24"×24") Nat/Ret	P 9,5	3	1,080	21,50	40	43,20	860	120x80x75
60*60 (24"×24") Lev/Ret	P 9,5	3	1,080	22,50	40	43,20	900	120x80x75
30*60 (12"×24") Nat/Ret	P 9,5	6	1,080	21,50	48	51,84	1032	120x80x75
30*60 (12"×24") Lev/Ret	P 9,5	6	1,080	22,50	48	51,84	1080	120x80x75

Pezzi Speciali / Special Pieces

30*60 (12"×24") Step Nat/Ret	P 9,5	6	1,080	21,50	36	-	-	-
6,5*119,5 (2½"×47½") Battiscopa Nat/Ret - Lev/Ret	P 9,5	8	0,621 m.l. 9,60	12,50	48	-	-	-
8*80 (3½"×31½") Battiscopa Nat/Ret - Lev/Ret	P 10,5	7	0,448 m.l. 5,60	11,00	65	-	-	-
8*60 (3½"×24") Battiscopa Nat/Ret - Lev/Ret	P 9,5	10	0,480 m.l. 6,00	11,00	72	-	-	-

*Attenzione: verificare in fase di ordine il codice e l'imballo (80*80)
*Note: In the ordering phase please check code and packaging (80*80)
*Bitteachten: Beim Bestellen bitte die Kodenummer und die Verpackung kontrollieren (80*80)
*Attention : Merci de vérifier emballage et la référence au moment de la commande (80*80)

Pezzi Speciali

Special pieces
Formstücke
Pièces spéciales

Battiscopa Nat/Ret 8*60 - 3½"×24" ± 9,5
Battiscopa Lev/Ret 8*60 - 3½"×24" ± 9,5

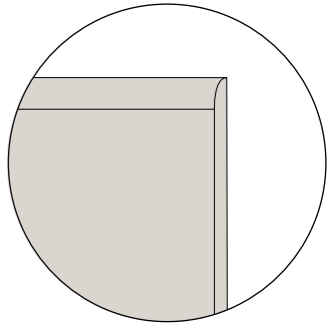
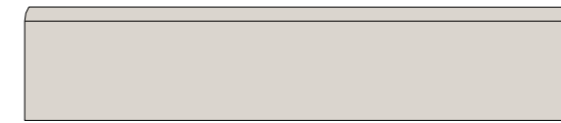

Battiscopa Nat/Ret 8*80 - 3½"×31½" ± 10,5
Battiscopa Lev/Ret 8*80 - 3½"×31½" ± 10,5

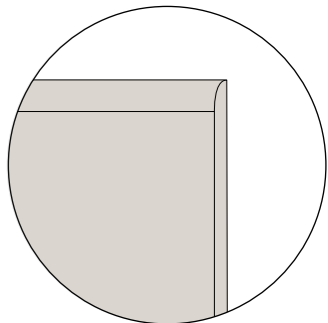
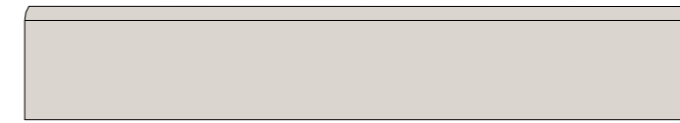

Battiscopa Nat/Ret 6,5*119,5 - 2½"×47½" ± 9,5
Battiscopa Lev/Ret 6,5*119,5 - 2½"×47½" ± 9,5

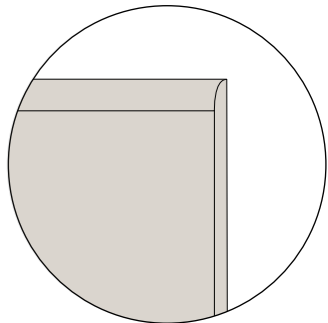

Step Nat/Ret 30*60 - 12"×24" ± 9,5
(Becco civetta e fresature tecniche - bullnose edge with grooves)

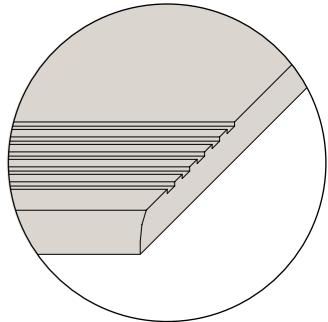

Reading Guide
Leseanleitung
Guide à la lecture

▼
▲
Spessore
Thickness
Stärke
Épaisseur

Variazione nelle sfumature di colore
Color shade variations
Variation der Farbnuancen
Variation des nuances de couleur

V1
Aspetto uniforme
Uniform appearance
Gleichförmiges aussehen
Aspect uniforme

V2
Variazione leggera
Slight variation
Leichte variation
Variation légère

V3
Variazione moderata
Moderate variation
Mäßige variation
Variation modeste

V4
Variazione casuale
Random variation
Zufällige variation
Variation fortuite

Tutti i formati sono nominali.

Gli spessori riportati in questo catalogo sono nominali e possono variare a seconda dei formati e delle finiture.

I colori e le caratteristiche estetiche dei prodotti sono quanto più possibile vicini a quelli reali, nei limiti consentiti dai processi di stampa.

All sizes are nominal.

The thickness mentioned on this catalogue are nominal and can be different according to the sizes and the finishes.

The colours and appearance features of the products are as close as possible to reality, within the limitation of the printing process.

Die Formate sind Nennwerte.

Die in diesem Katalog angegebenen Fliesenstärke sind nominal und können, je nach Format oder Oberfläche, verschieden sein.

Die Farben und die ästhetischen Eigenschaften der Produkte entsprechen der Wirklichkeit, innerhalb den von dem Druckverfahren erlaubten Grenzen.

Tous les formats sont nominaux.

Les épaisseurs reportées sur ce catalogue sont nominales et peuvent varier suivant les formats et les finitions.

Les couleurs et les caractéristiques esthétiques sont fidèles aux couleurs et caractéristiques réelles dans les limites des procédés d'impression.

Una storia tutta italiana

Piemme dal 1962, anno della sua fondazione, è protagonista indiscussa del vero Made in Italy, quello fatto di eccellenza, passione e creatività. Oggi tutti i materiali Piemme sono prodotti con tecnologia d'avanguardia come la decorazione digitale inkjet HD, la cottura in forni ad energia pulita a recupero di calore, la rettifica e levigatura in linea "one roof" e la verifica elettronica dello standard qualitativo.

An all-Italian story

Since 1962, the year of its foundation, Piemme has been the undisputed protagonist of real Made in Italy, that which consists of excellence, passion and creativity. Today all Piemme materials are made using cutting-edge technology such as HD inkjet digital decoration, firing in heat-recycling clean-energy kilns, "one roof" grinding and polishing line and electronic quality standard control.

Eine ganz italienische Geschichte

Seit dem Gründungsjahr 1962 ist Piemme ein unangefochtener Hauptakteur des echten Made in Italy: jenem, das auf Exzellenz, Leidenschaft und Kreativität gründet. Alle Piemme Erzeugnisse werden heute unter Einsatz von Spitzentechnologie produziert, wie zum Beispiel mit der digitalen Inkjet-Dekoration, dem Brennen in Öfen mit grüner Energie und Wärmerückgewinnung, dem Schleifen und Polieren in der Linie „unter einem Dach“ sowie der elektronischen Prüfung des Qualitätsniveaus.

Une histoire toute italienne

Depuis 1962, l'année de sa fondation, Piemme est la protagoniste indiscutée du Made in Italy, basé sur l'excellence, la passion et la créativité. Aujourd'hui toutes les phases du cycle de fabrication Piemme sont issues d'une technologie à l'avant-garde comme la décoration numérique inkjet HD, la cuisson dans des fours à énergie propre et à récupération de chaleur, la rectification et le polissage en ligne "one roof" et la vérification électronique de la qualité.

CERAMICHE PIEMME

FLOOR AND MORE

INDUSTRIE CERAMICHE PIEMME S.P.A.
VIA DEL CROCIALE 42/44, 41042 FIORANO (MO) - ITALY
T. +39 0536.849111 - F. +39 0536.849402
WWW.CERAMICHEPIEMME.IT - INFO@CERAMICHEPIEMME.IT